

Ionut Purica & Marioara Iordan

EU and the new century's energy conflicts

Electronic Publications of Pan-European Institute 15/2008

EU and the new century's energy conflicts

Ionut Purica¹ & Marioara Iordan²

15/2008

**Electronic Publications of
Pan-European Institute**

www.tse.fi/pei

The authors are thanking the Finnish Academy whose grants (128269 and 128297) made possible making this paper during their stay at the Pan European Institute in Turku; all opinions and ideas expressed here belong to the authors alone and not to any of the entities mentioned above.

¹ **Dr. Ionut Purica:** after having built nuclear power plants and taken a PhD in energy engineering, I.Purica applied nonlinear models to assess the risk of the Italian gas network with ENEA and has been an associate researcher in ICTP Trieste. Back to Romania he lead the international projects of the Romanian Power Company RENEL and then worked as a project officer for energy and infrastructure in the World Bank. He has a second PhD in economics of power markets and teaches risk analysis and project management to master of science courses in Romania, Moreover, he does consultancy in energy and climate change (US, EU, Japan) being affiliated with the institute of Economic Forecasting of the Romanian Academy

² **Dr. Marioara Iordan:** an economist with a PhD in economics she has extensive experience in regional economic planning and development modeling, with an accent on demand side behavioral economics. Ms.Iordan is Deputy director of the Institute of Economic Forecasting of the Romanian Academy and is involved in several national programs related to sustainable development and EU convergence and competitiveness.

CONTENTS

ABSTRACT	3
1 NONLINEAR BEHAVIOR AND CONFLICTS	5
1.1 The butterfly effect	5
1.2 Parabolic effect and bifurcation	6
1.3 Changing limits and rules of the game	6
1.4 New structures in the globalization process	7
1.5 Spontaneous structure formation	8
1.6 Indicators of crises and Models to describe the new behavior	8
2 ENERGY AND NONLINEAR BEHAVIOR	10
3 RATING THE ENERGY RELATED BEHAVIOR OF EU COUNTRIES	22
3.1 Local versus global perception – an index of measurement	22
3.2 Selected countries' results	24
4 CONCLUSIONS	28
REFERENCES	29

LIST OF FIGURES

FIGURE 1	PRODUCTION ON GAS	10
FIGURE 2	GAS PIPELINES IN THE EAST OF THE EU	11
FIGURE 3	NORD STREAM PROJECT	12
FIGURE 4	PIPELINE PROJECTS IN THE SOUTH	12
FIGURE 5	NORTH AND SOUTH PARTS OF GAS RING	13
FIGURE 6	EXISTING AND POTENTIAL GAS HUBS IN EUROPE	14
FIGURE 7	GAS MARKETS IN EU	15
FIGURE 8	VULNERABILITY OF EU COUNTRIES TO GAS IMPORT	15
FIGURE 9	EUROPEAN UNION WHOLESALE GAS AND OIL PRICES	16
FIGURE 10	CO2 EMISSIONS - BASELINE AND HIGH RES AND ENERGY EFFICIENCY SCENARIOS	16
FIGURE 11	EUROPEAN HYDROGEN ROADMAP	18
FIGURE 12	NUCLEAR POWER CAPACITY EVOLUTION	19
FIGURE 13	ELECTRICITY FROM NUCLEAR POWER	20
FIGURE 14	VULNERABILITY INDEXES FOR NATURAL GAS.	24
FIGURE 15	BETA – BEHAVIOR COEFFICIENT FOR ROMANIA	25
FIGURE 16	BETA BEHAVIOR COEFFICIENT FOR FINLAND	25
FIGURE 17	BETA BEHAVIOR COEFFICIENT FOR GERMANY	25
FIGURE 18	POTENTIAL FUNCTION REPRESENTATION OF MULTI PARAMETER DYNAMIC FOR EU	26

LIST OF TABLES

TABLE 1	SUPPLY AND DEMAND BALANCE, EU-27	11
TABLE 2	SHARE OF ENERGY SOURCES IN TOTAL ENERGY CONSUMPTIONS	23
TABLE 3	GROSS INLAND CONSUMPTION IN EU-27 AND EUROPE -30	23
TABLE 4	GAS AND OIL VULNERABILITY INDEXES	24

Abstract

When one was considering conflicts in the second half of the twentieth century in Europe the first thing coming to mind were the 40000 tanks of the Warsaw Pact ready to reach Lisbon in a short time, and the military countermeasures of NATO. In the mean time USSR had disappeared and after 11.Sep.2001 it became clear that an activity that was done by governments has been privatized: War is privatized. Individuals and organizations may do war on governments, unfortunately with significant results. War is not the same anylonger. For instance, instead of bombing a strategic objective (say a refinery) for 5 hours, socio-economic conditions are created for it to economically decay by itself in five years. Its only the time constant that is different; the result is the same. Among the socio economic conditions are the availability and price of energy. Thus, energy becomes more important in the above context being also looked at from a security point of view. In order to better understand the new behavior related to today's dynamics one needs to go beyond the usual linear thinking of twenty years ago and consider the benefits of using (understanding first) nonlinear models. We will, in what follows, make some considerations on the nonlinear behavior in today's conflicts (not to be understood as merely military ones) and pass on to a brief observation of the convergence of EU energy policy, exposed to a trend of facing a supply side driven energy situation. The paper ends with an analysis of the possibility to introduce an index aimed at rating the deviation of each member country from a potentially unique, Commission driven, EU energy policy that will represent a first step toward a demand side driven energy situation in the EU. If the financial policy of the EU has resulted into a real unification based on the introduction of the Euro and of a Central Bank for the whole EU, and if labour policy is developing toward a blue working card valid for the whole EU, the energy policy is only now starting to strive toward a unique approach. Energy was not exactly having an 'acquis communautaire' in the sense of convergent member countries behavior. The important thing to also take into consideration is that in time of crises the role of governments is increasing and the existence of an integer that is greater than the sum of its parts, i.e. the EU, may represent a facility to be seriously considered by the corporations in the EU economic space. The creation of a synchronisation platform among CE policies and corporative ones related to energy may bring value to the situation of the energy systems of the EU. The market approach based on unbundling inside the EU, lacking a coherent correlation at the governmental level (local and EU) may not be resilient enough to face strong government controlled energy

suppliers both in Russia and in North Africa. With a proper rating index we would at least know where we stand, thus making it easier to decide response measures for development.

1 Nonlinear behavior and conflicts

The last decade of the XX-th century has witnessed new structures coming high on the logistic penetration curve. With this a redistribution of roles and functions is seen in the World dynamics which, sometime, is a surprise even to those who advocate it most. In 1994 in London, while discussing about the unbundling and privatization of the former power monopoly of England, into several power companies in competition on the power market, I was asked about the situation in Romania. My answer was that the process had also started in Romania, only higher up in the social structure: they started unbundling the political monopoly there (Communist Party), into several political companies (Parties), in competition on the political market (elections). The process continues in the economic infrastructures having reached the power sector in 1999.

This shows that the evolution of new structures now a day is reaching sectors which, till now, were unthinkable: WAR IS PRIVATIZED. A function that was definitely thought to belong to governments, is now shown to be done by individuals and/or private organizations who declare (and unfortunately, as 11th of September 2001 had shown, make) war to governments.

There is a nonlinear world out there, totally different from the linear evolution of the fifties and the sixties. To understand this behavior, one must extend the traditional view and devise new models and parameters which should make prediction of crises/conflicts possible and suggest the ways to avoid or solve them. We are describing below the basic features of the nonlinear behavior. Implementing present days data, may result in straight forward conclusions about ongoing conflicts such as India-Pakistan, etc. Our suggestion is to support the start of a systematic activity on developing and implementing the new approach to present world dynamics. Fortunately we have the nonlinear models at hand.

1.1 *The butterfly effect*

Volatility and variation in the world of today mark the out coming of a time dominated approach to dealing with the world evolution. In the traditional cultures of today having geographically dominated intercorelations, new structures are penetrating imbedding commercial/financial dominated cultures which extend planet wide. Time is manifesting

itself as important through the occurrence of 'second order money' i.e. price of options and futures which do not relate to an asset but to the variation of that asset's price.

This high dynamics is allowing small changes of initial conditions in various processes to result in large effect consequences e.g. financial crises, terrorist actions - where one individual, or a small number of them, may drastically influence the, believed to be, rock solid system. The price to pay for the increasing complexity of our evolution's sustaining structures is the larger possibility of 'butterfly effects' and of their potential use by even single individuals. This is making sometimes one individual equal to a fully developed structure in terms of its momentary power to produce large consequences.

1.2 Parabolic effect and bifurcation

We are frequently talking about extremes but, when it is the moment to act our reaction is polarized toward one extreme unconsciously reducing the chances of the other. Take as an example the plane hijacking: what if, instead of over controlling the passengers for guns, every passenger would be given a loaded gun when boarding the plane (including the hijacker). How many hijackers would dare draw out a gun, in that plane, knowing they may have another hundred guns pointed at them instantly? Another case this time of using the other extreme is finding the arms status of Iraq: instead of sending people in the dark (undercover) a bright light was used (UN inspectors) giving the same result - blind the Iraqi administration into giving the information away.

Keeping in mind all the potential action ways and being able to switch among them as needed. No decision is final if it leads to a foreseeable disaster. This statement is bringing us to another second order effect in today's world: changing the limits and the rules of the game. If this is done for the benefit of the world and of the environment it is called sustainability. Below we discuss the case of its perception from a risk viewpoint related to international relations.

1.3 Changing limits and rules of the game

It is in the human nature to avoid uncertainty. We are prepared to accept evil if it comes wrapped in a set of well defined rules. 11. Sep. 2001 has changed the existing rules of the 'terrorist hijacks plane' game. The new limits of the game are not settled yet. It is the fear

of the unknown that creates more impact than the event in itself. The so called 'crisis' starts as a state of mind induced by reaching or surpassing previously accepted limits.

The same disappearance of the old limits occurs in the interstate relationships: 'Who is not with us is against us' is back on the international relations stage. Moreover, since now this message is a monologue at the state level i.e. USA only, the possible results it may obtain, given the parabolic nature of the possible reactions are either an accelerated globalization of the world (other limits disappearing), or the polarization of a strong counter reaction based on dormant concepts now a days like manifested religion in matters of economic and social structure. In any case the values of our present civilization will modify as a price to pay for the change.

1.4 New structures in the globalization process

If we go back in the evolution of human society on the planet, three trends of expansion may be identified:

(i) a geographical trend which started with the Phoenicians and Greeks, followed by the Vikings and then by Columbus, Magellan, Cook, etc. and ending with the satellites age when saturation settles in on geographical discoveries. This wave has triggered human structures based on geographical like parameters: territory, language, traditional culture. A period of cca 400 years passed from the moment of Columbus to the nation based structures (states) in the XIX-th century.

(ii) the second wave came with the movement of mass : raw materials, products, etc. that changed the main parameters of the new structures to cycles of production and consumption. The control of resources at source or on their fluxes, the development of larger production-transport-distribution-consumption structures is the basis of this wave. Having started in the XVII-th century, the result of this wave is seen nowadays (again 400 years later) in the corporation like structures not depending on geography but on commercial cycles, and having their own internal cultures. The commercial unification of the planet with structures like World Trade Organization slowly phasing out the United Nations Organization is typical for this situation.

(iii) the third wave is the information wave. This is starting to develop only now. When we say information we do not refer only to electronic info but, also to the genetic one; to the

dynamic information on the evolution of various processes, etc. Will we, for example, genetically engineer the next generations of humans to be smaller such as to allow more to live in the finite space of the planet thus, solving the demographic problem. Our technologies will follow us into the smaller world through the mechatronics and nanotechnologies that start to develop now. Or, alternatively, are we going to act in time prolonging our lives enough to colonize the universe. Other scenarios are possible but we will probably have to wait for the next 400 years too see the result.

1.5 Spontaneous structure formation

The above topics were raised to make an important point i.e. that along with the structures on the main stream line there are other structures occurring in parallel. Family type organizations be they Rockefellers or Corleones (at the two extremes) were coexisting with the nation based states. The terrorist organizations of today are following the same pattern of coexisting, but instead of building they, frequently fight the other structures. Shall we envisage a United Structures Organization where, along with nations, there may be present the ABBs and General Electrics of the world as well as the AlQaedas of the world?

Fashion effect (we call it like this because of the similarity with fashion exposed behavior) as a typical collective effect, occurs the moment a given pattern of behavior is settled in, justified either by the right of power or by the right of justice, or both, everybody starts using it to solve its own problems. For example the fight of USA against terrorism triggers intensified activity between Israelis and Palestinians, between India and Pakistan, etc. The justification for such activity is, in each case, the fight against terrorism. The sad thing is that in each case it is a 'fight against' and not a 'negotiation with', such that to reach a change of the behavior pattern.

1.6 Indicators of crises and Models to describe the new behavior

The last twenty years have witnessed the development of non-linear mathematical models that are applied more and more widely. Given the characteristics above for the new type of behavior in the international structures, the imbedded nonlinearity allows for, and even requires, the use of complex models.

In all this dynamic of the human structures is there some indicator of the possibility to predict or, at least, to recognize early enough, the occurrence of a terrorist structure? The closest example of this type that comes to mind now is the onset of turbulence in fluids. In the physics of flowing fluids there are various aggregated indicators (Reynolds, Prandl, Nusselt, etc.) from basic physical parameters which provide the information about the onset of change in the system's behavior. In the description of human structures behavior the most complex indicators are just aggregates of two basic parameters e.g. GDP per capita, etc. When are we going to witness the equivalent of the Navier-Stokes fluid flow equations in economics and finance. Black-Scholes is a good start but, there is a need for process describing equations e.g. of the interaction type between individuals and structured groups of individuals (companies) similar to the ones describing neutrons interactions with nuclei. If these models will develop then, our understanding, i.e. prediction capability, for the human structures dynamics will be based on indicators which will look definitely exotic by the standards of today. It is very probable that these indicators will allow the prediction of the occurrence of ordered dynamical structures in a similar manner to the Benard-Taylor processes in plasma or turbulent fluids with external temperature fields. Moreover, these models allow for small individuals to trigger the change of the whole system - back to the butterfly effect. Other types of models, are the ones based on Rene Thom's 'Catastrophe Theory' (1975).

One application of the nonlinear approaches described above had to do with technology versus economic adaptability. In Reagan's time the USA changed the rules of the action by developing technology very fast (strategic defense initiative) that forced the USSR's economy to adapt faster than they could keep the pace in the given conditions of those years. Result: open economy and various former soviet republics spinning off into new countries on the map of the World.

It is clear that only small conflicts may involve military action, the large conflicts are becoming more complex by our today standards and are fought in a totally different way.

2 Energy and nonlinear behavior

Before discussing energy we must mention that the EU has a coherent financial policy leading to a common currency and a central Bank, it is implementing a comprehensive labor policy with the introduction of the blue card and other measures, but, there is as yet no comprehensive energy policy that would encompass e.g. a unique importing agency for all EU. The energy policy of the EU has just started to structure up from the power markets to timely objectives such as the 3 x 20% recent requirements.

Let us first look at the EU energy situation to understand the feeling of urgency for a common energy policy. The gas and oil reserves in the Nord Sea are depleting and the opening of new ones (assuming they are there) takes time and high costs. The main source of gas in the North of EU is Russia. Caspian region gas and oil are partially controlled by Russia and are finding more profitable markets in China and India. North African gas is another source for EU but Libya and Algeria are more close to the Arab world than to EU. Other 'classic' (Arabian, Venezuela, Nigeria, etc.) oil resources are under competition with USA and Japan as well as China these days.

Figure 1 Production on gas

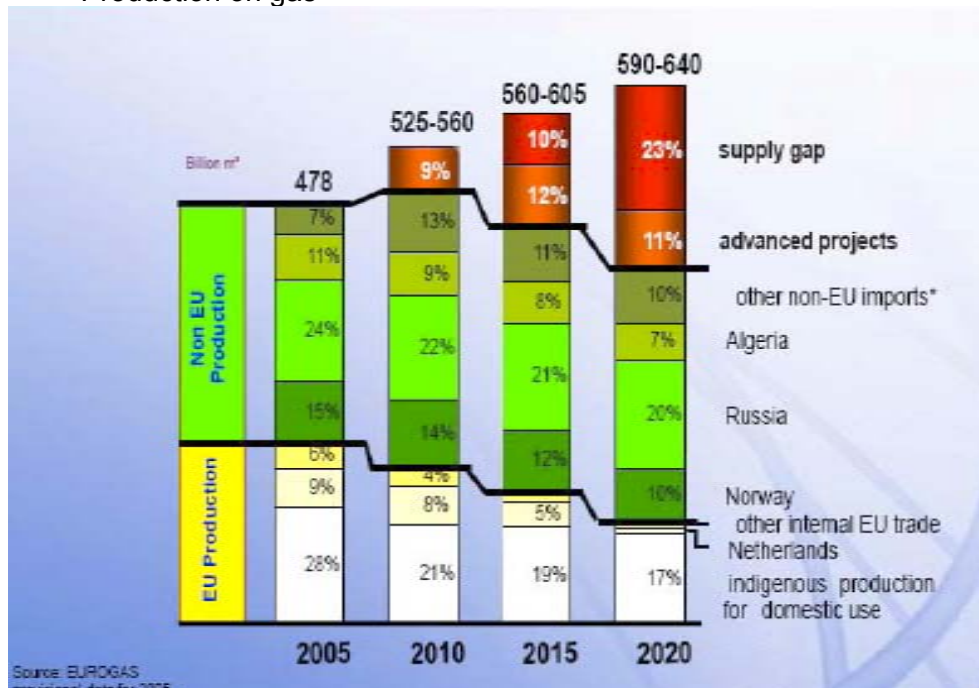

Table 1 Supply and demand balance, EU-27

EU-27 S/D balance 2015 bcm/a			
	2006	2010	2015
Demand	532,0	580,0	629,0
Supplies			
UK	83,4	68,0	40,0
NL	77,7	70,0	60,0
Other EU	56,1	58,0	48,0
Norway	85,5	105,1	120,0
Algeria/pipe	36,0	45,0	52,0
Lybia/pipe	7,7	8,0	8,0
LNG	52,0	100-130	50-130
Call on Russia	130	99-126	171-251

Source; CIEP

One nonlinear effect to mention here is that geographical control becomes irrelevant. One does not necessarily need to occupy geographically in order to control say gas resources' commercial dynamic. Following the example of OPEC, a similar organisation of gas producers was formed (Russia, Iran and Qatar). Probably other producers from the Caspian area will join in at given future moments. Not to neglect the North African gas suppliers that were visited by Russian high officials recently.

Figure 2 Gas pipelines in the East of the EU



Source EIA

Figure 3 Nord Stream project



Source EIA

Figure 4 Pipeline projects in the South

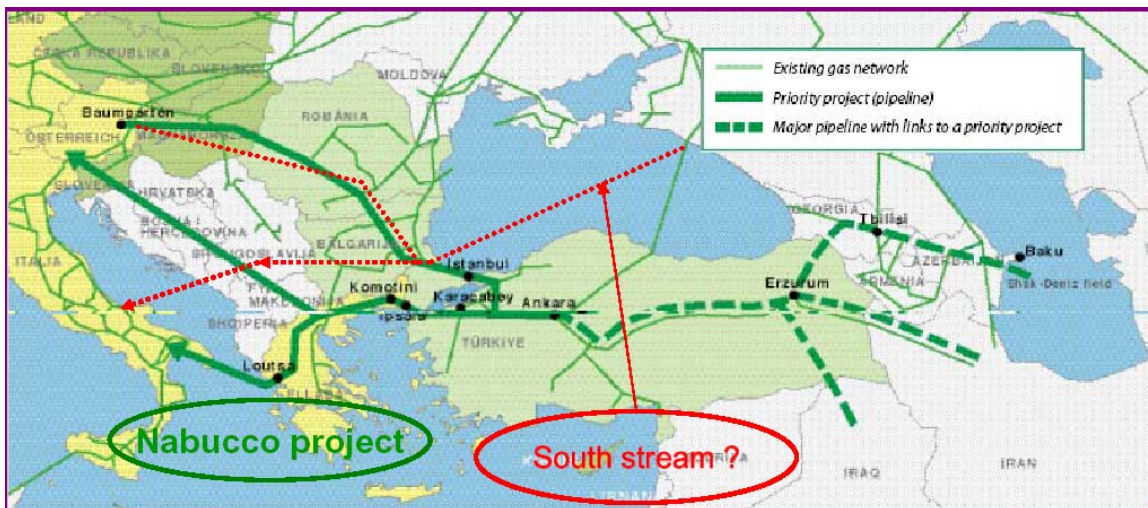

Source EIA

Figure 5 North and south parts of gas ring

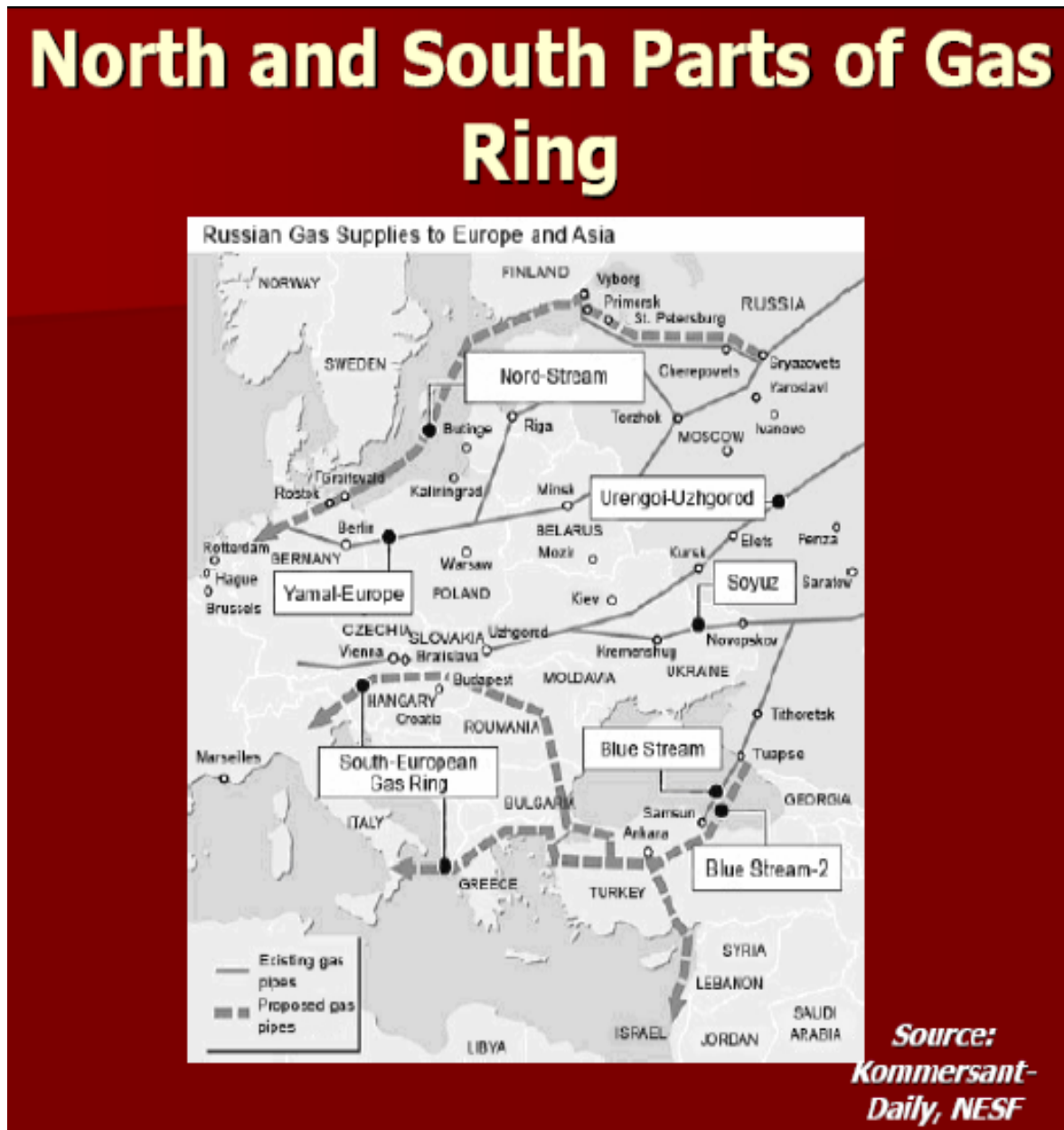

Source IEA

Figure 6 Existing and potential gas hubs in Europe

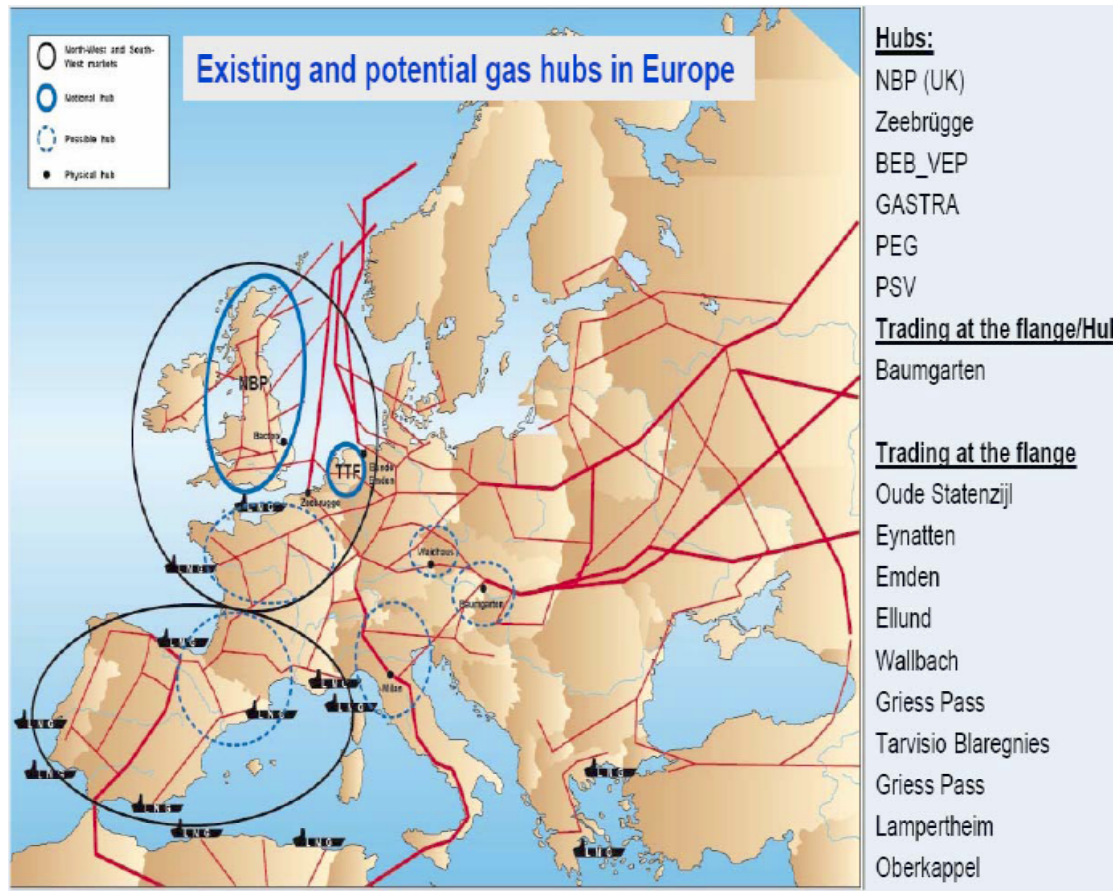

N.B. Romania is also a good candidate for Gas Hubs

All the actions mentioned above lead to a supply side driven gas market for the EU (Russia should be admired for a consistent policy toward this goal). We think it is good time now to have a consolidation on the demand side, lacking which EU, that is not a military leader as in the XIX-th century, not a technological leader like in the XX-th century, may face an identity crisis when its control on the energy resources will completely disappear.

Figure 7 Gas markets in EU

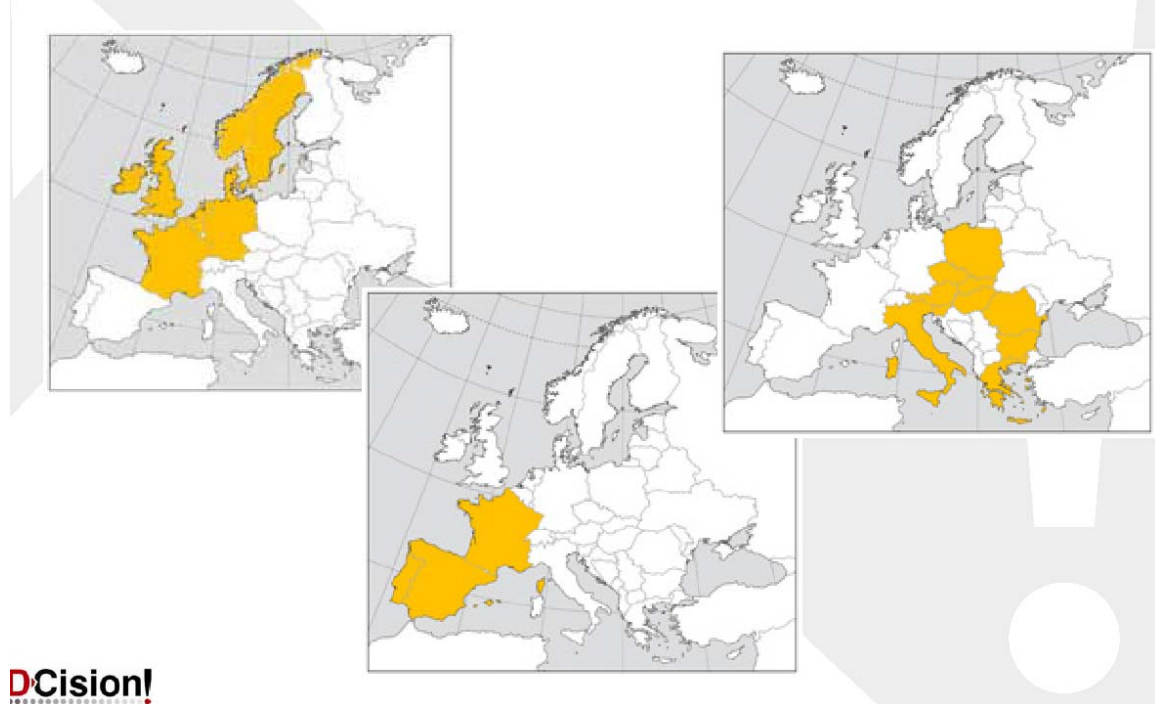
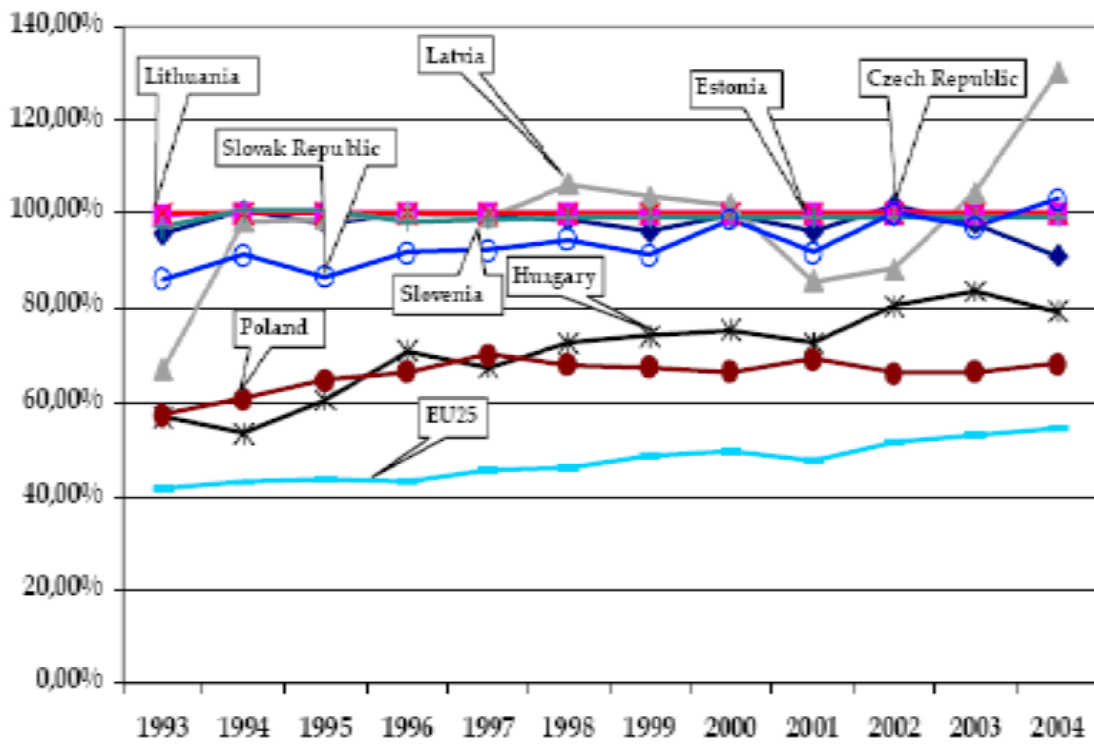
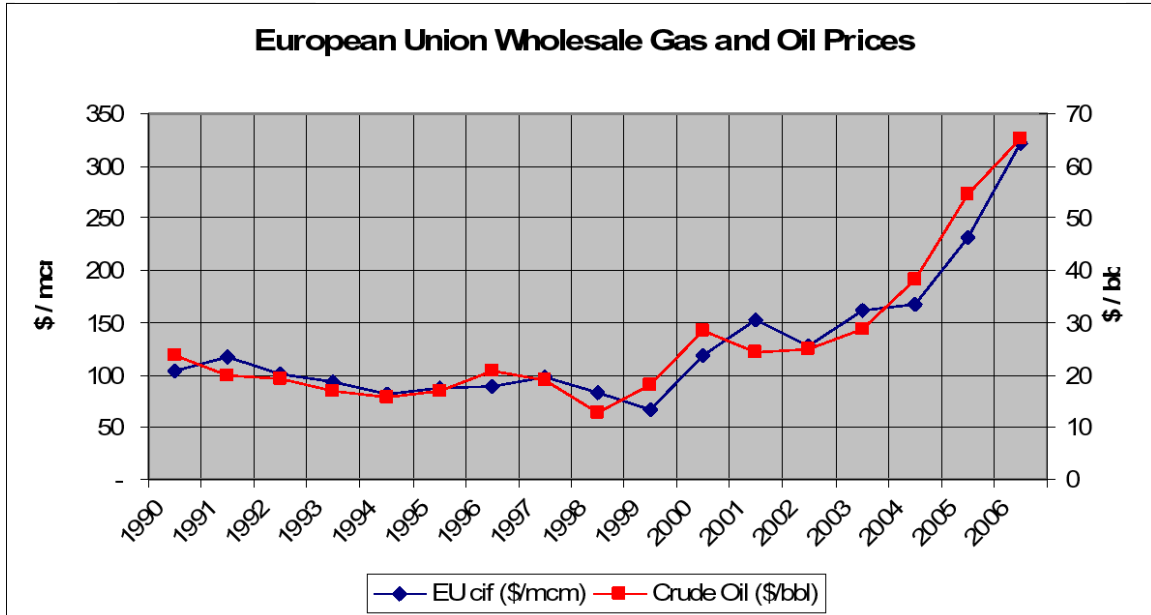

Figure 8 Vulnerability of EU countries to gas import



Moreover, the price increase of gas is constant in the last years. In the above conditions what are the response actions related to energy vulnerability decrease and to security?

Figure 9 European Union wholesale gas and oil prices



USA and EU are developing alternative energy technologies (renewables, hydrogen systems, nuclear power and even coal gaseification) that lead, on a medium term, to decoupling from the hydrocarbures based development. The above will also contribute to reducing CO2 emissions with benefic effects on the climate change.

Figure 10 CO2 emissions - Baseline and high RES and energy efficiency scenarios

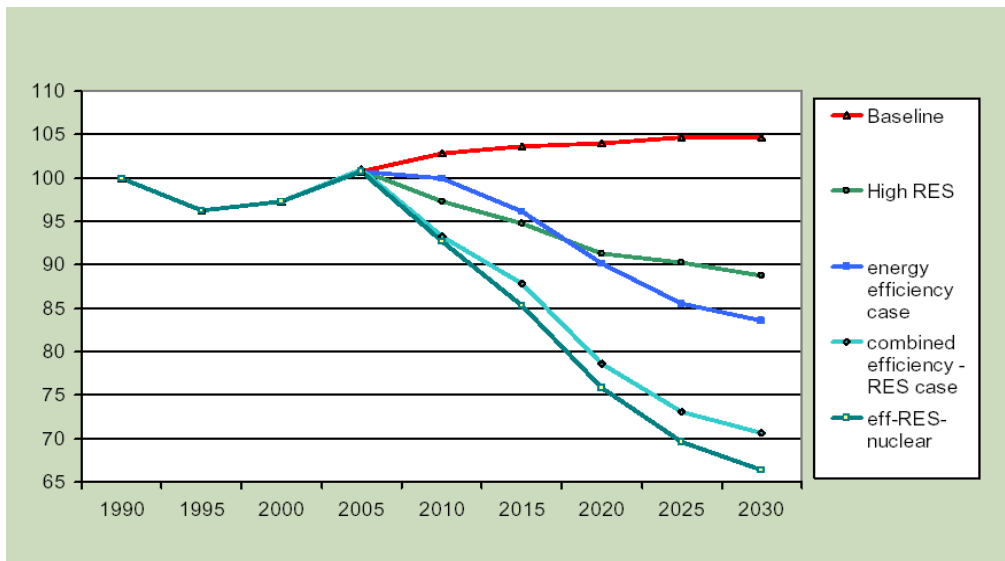

The development and implementation of the above mentioned technologies seems to be on an up trend with a sustained rate (that will probably be accelerated by the present financial crisis as a means to create more jobs).

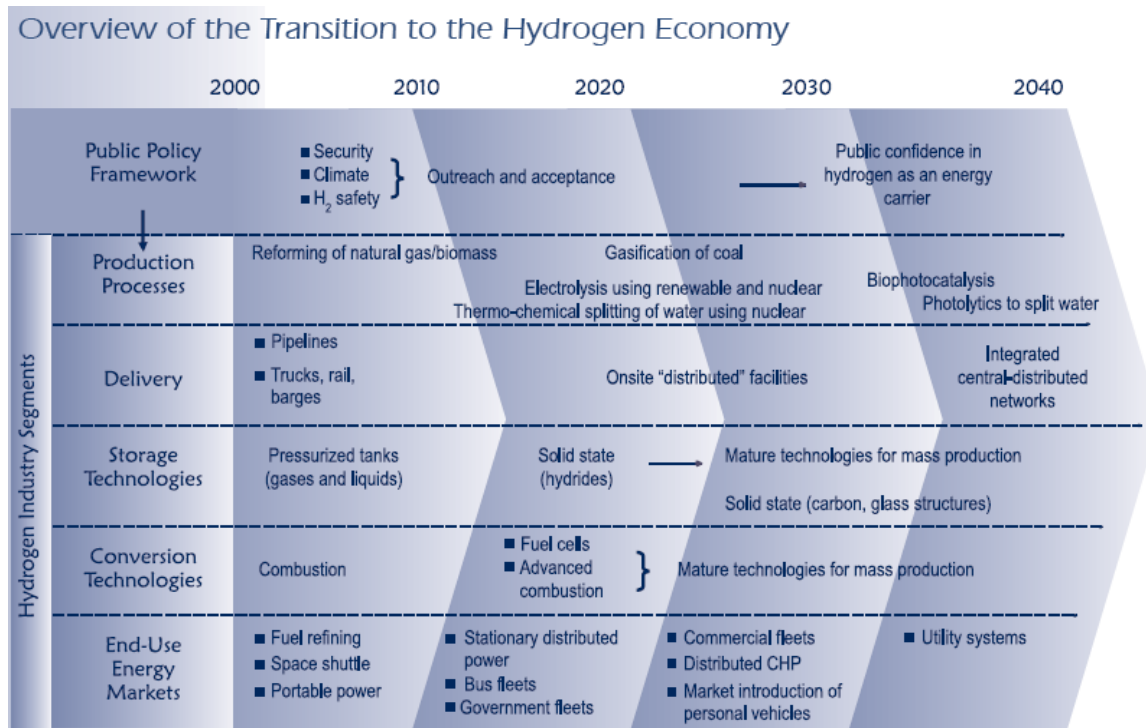

Source EIA

Any way the penetration of new technologies follows a logistic curve i.e. slower at the beginning, then sudden and saturating toward the end. It seems that we are now in the penetration period and the hope is that the full penetration will be done with a faster rate than the oil and gas depletion one.

If this happens, then, NATO countries (that may also be considered as forming an economic league of the Nord) will be in a doubly advantageous position: (i) decrease of economic and political vulnerability to external supply sources; (ii) capacity to influence the price of oil from supply sources that, especially USA, are controlling in the Arab world, Africa and South America.

One example of such oil price control action correlated to money (another kind of complex effect) is the increase in investment credits, resulting from maintaining the oil price at high values for two-three years, based on the belief that debt can be paid from oil revenues.

The sudden drop in the price of oil leaves a lot of this development debt to be covered from other sources (such as less military expenditure, or reduction of social expenses with associated turmoil) bringing more banks related control of various oil supply side economies. This time USA should be admired.

Figure 11 European hydrogen roadmap

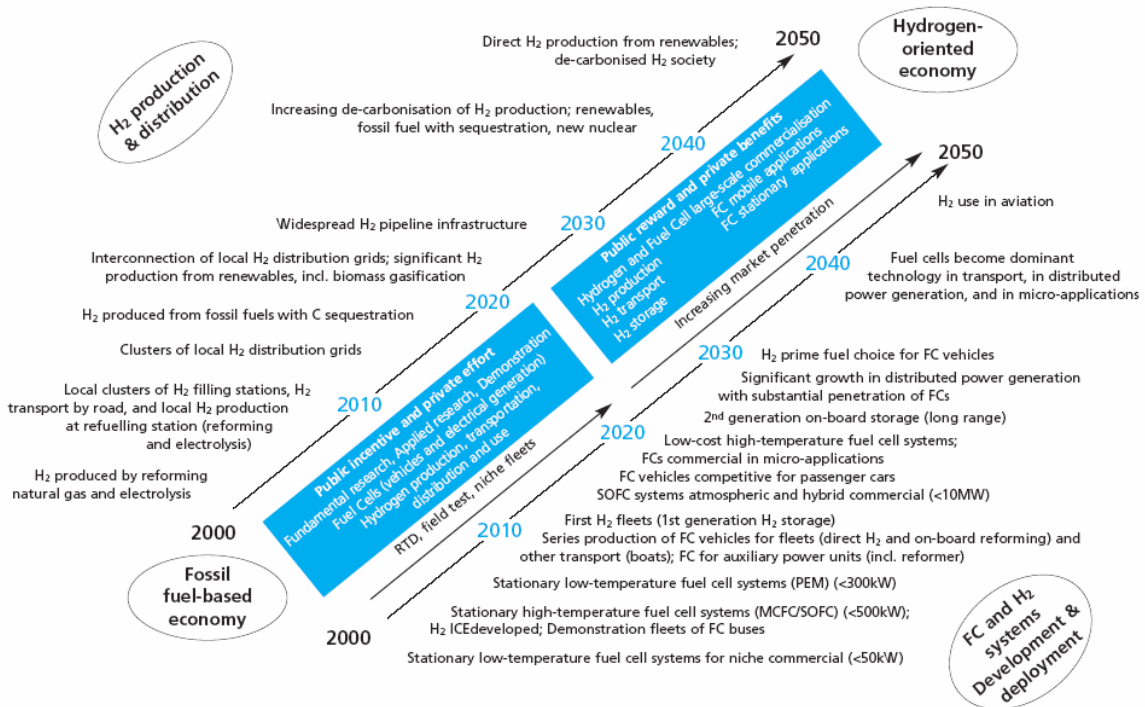

Figure 4: Skeleton proposal for European hydrogen and fuel cell roadmap

Source IEA

One may understand that clean energy technologies is not limited to NATO countries but it is proposed to all countries of the World. The medium term effect will be a change of power in the World. We were saying above that war is done with a different time constant; if all countries will produce alternative energy, then the power given by the supply of oil and gas will be dramatically reduced, with a change of the power structure in the World toward those who have technological knowledge and other resources, such as Lithium for the batteries. This is also another type of war.

The world of today is more complicated than the bipolar one of thirty five years ago. The oil consumption of China increased 6-7 times inducing a diversification of searching for resources that gives a global status to the old empire of mid lands that decided in the XV-th century to stop maritime exploration that they had started in force and to strengthen the

northern frontier with an uncommon great wall. Along with China there is India, also looking for energy, as well as smaller Asian emerging economies. South America has also large economies in search of energy; and the exemple of Brasil that ,grows' its methanol in the fields is relevant to energy independence.

Bio fuel is raising the price of food and the structure of food exports – a new type of complex correlation is showing up. For example, are we going to see an increased imigration of Mexicans to the USA because less US grown corn goes to feed Mexico while more is used for moving US cars?

On a diferent line let's not forghet that at the cross road between military and energy activities there are elements of environmental pollution. For example the smoke of the burning oil fields left over by the retreating Iraki army from Kuwait, in 1991, had a significant effect in the Worlds CO2 emissions.

One other aspect to mention on security is the fact that construction of more nuclear power plants implies more fuel and more waste circulatin in the World. This will increase also the cost of maintaining the security of such potential sources of nuclear bomb material.

Figure 12 Nuclear Power capacity evolution

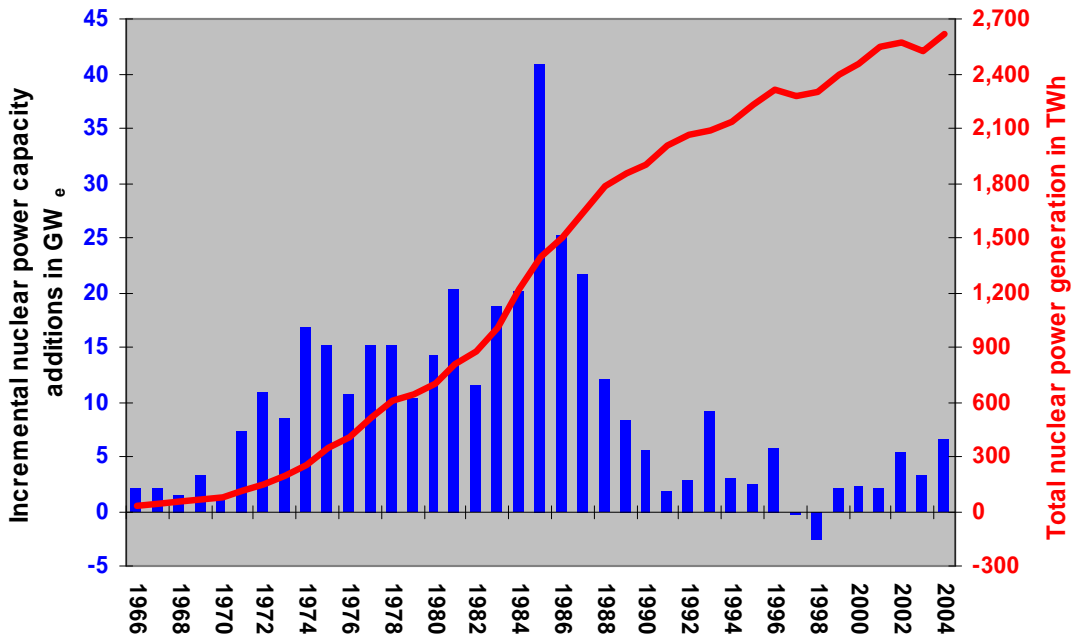

Source IAEA

Figure 13 Electricity from nuclear power

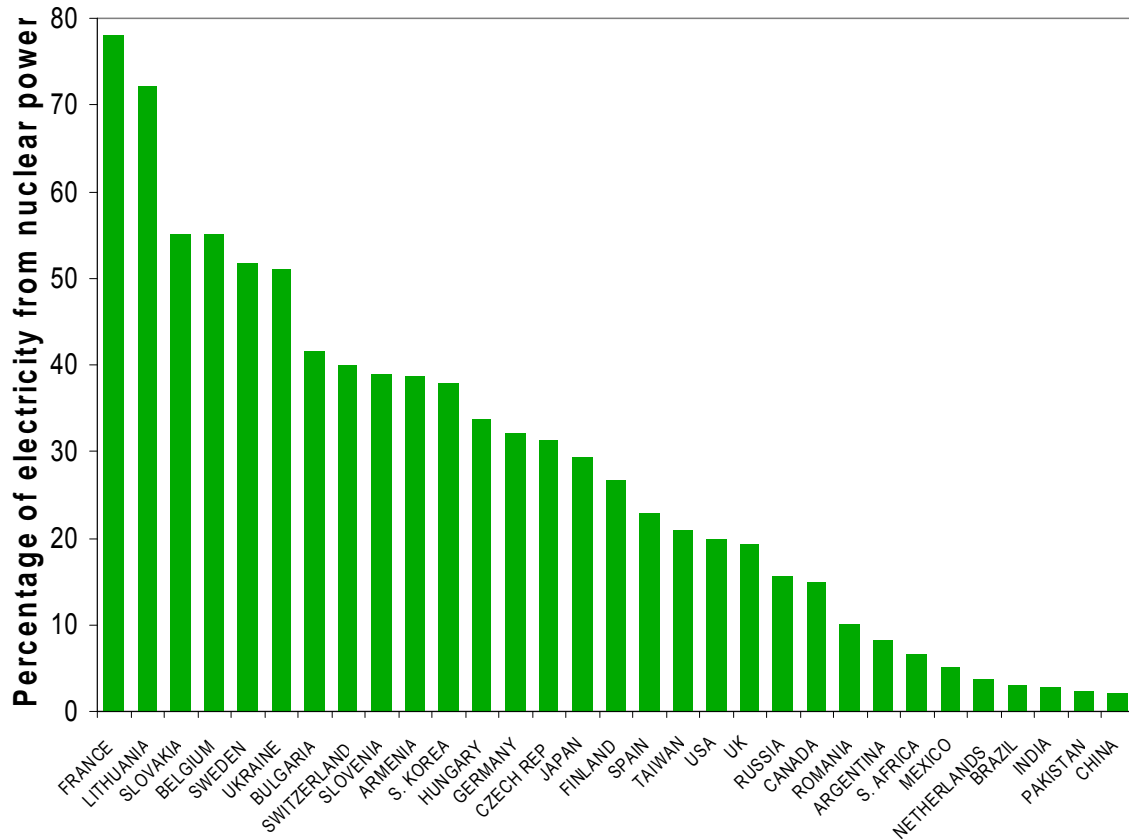

Source IAEA

Obviously the development of new technologies leads to outstanding socio-economic effects associated to the structural change of the economies and to the development of new production domains.

Imagine a world where everybody would have an energy generating system for electricity and heat based on wind, hydro, geothermal, biomass, solar as each type of energy is available in the surrounding environment. The system may also dissociate water producing Hydrogen for transport; and people will wear infrared goggles to see at night (no need for public lighting anylonger). Combining this with extended personalized communication devices we will have a World whose aspect will be very unclassical to what we are accustomed today. For example the criterion by which civilisation is measured according to the increased percentage of people in the cities may have no relevance whatsoever. We do not know how the energy security will be looked at in such a world or even if there will be an energy security issue anylonger.

Sun Tzi, in his book *The Art of War* said that the best war is the one won without military fight. It seems that the dynamic of today's World, with its unclassical time constants, brings the concept of security at the level of understanding and protecting a nation, or group of nations, from the situation when they think they are doing something because they want it, when, in fact, they are doing it because others want them to do it.

3 Rating the energy related behavior of EU Countries

The next 20 years will represent a critical period for the EU. At least from the energy point of view EU will not be independent in the sense that the degree of vulnerability measured as imports over gross inland domestic consumption will increase at least in the case of natural gas and of oil.

The most recent prediction scenarios are clearly pointing at this future. Several groups in the EU are using various models to make predictions on energy systems evolution obtaining various types of accuracy. What is missing, at least in our view expressed here, is a way to go further into finding a way to simply describe the connection between EU behavior, as a whole, versus single member country behavior. Moreover, the actions of the Commission and of the various governments seem sometimes divergent based on the difference between general level and local level perceptions of the vulnerability to energy supply.

The EU is looking at energy in a triad way: (i) generation, (ii) efficient consumption, (iii) climate change. This is the basis for the recent 3 x 20% policy:

- 20% more renewable (n.b. nuclear is also coming back strongly) is dedicated not only to reduce CO2 emissions but also to diminish gas and oil dependency.
- 20% more efficient consumption is finally coming to change our technologies and also our way of living.
- 20% reduction of CO2 emissions is further contributing to decouple development from carbon based energy generation.

3.1 Local versus global perception – an index of measurement

EU Commission (2007) has issued a very comprehensive report on Energy and Transport evolution scenarios till 2030. It is based on the PRIMES model that is a developed tool with a good level of detail and credibility.

The tables 2 and 3 below are taken from this report as giving a view on the share of energy resources in total energy consumption and of the gross inland consumption in EU-27 and Europe -30

Table 2 Share of energy sources in total energy consumptions (in %):

	Solid fuels	Oil	Gas	Nuclear	Renewables
1990	27.8	38.3	16.7	12.7	4.4
2000	18.5	38.4	22.8	14.4	5.8
2010	15.8	36.9	25.5	13.7	7.9
2020	13.8	35.5	28.1	12.1	10.4
2030	15.5	33.8	27.3	11.1	12.2

Table 3 Gross inland consumption in EU-27 and Europe -30

	1990	2000	2010	2020	2030
EU-25	1556.2	1653.8	1812.5	1885.3	1895.2
BU,RO	89.3	55.3	65.9	84.5	97.1
EU-27	1645.5	1709.1	1878.5	1969.8	1992.3
TU,NO,SW	106.1	130.0	153.8	201.7	258.6
Europe-30	1751.6	1839.1	2032.2	2171.5	2250.9
	90/00	00/10	10/20	20/30	00/30
EU-25	0.6	0.9	0.4	0.1	0.5
BU,RO	-4.7	1.8	2.5	1.4	1.9
EU-27	0.4	0.9	0.5	0.1	0.5
TU,NO,SW	2.1	1.7	2.8	2.5	2.3
Europe-30	0.5	1.0	0.7	0.4	0.7

The approach we are proposing takes into account the evolution scenario for the whole EU – that integrates energy supply and consumption on a continental scale – and the evolution scenarios for each member country (EU-27) and Europe 30.

Since our paper is just suggesting the method, we have not made the full range of country calculations (that required a more elaborate program) but, we are presenting the approach for selected countries.

The basic idea is to use the evolution data for EU and that for each country and determine the country behavior versus the whole EU by making a linear regression of the two sets of data – the resulting slope would be a significant index. Given that this approach is close to the calculation of the Beta index for companies acting in given markets, we will call it a beta index for the behavior of each country. We must underline here that the values involved in the linear regression are not those of the income (like in the case of companies) but the ones of the vulnerability index (energy import on gross inland consumption) discussed above.

3.2 Selected countries' results

In order to see how such an index could describe energy related behavior of countries we have considered: (i) an EU member country having its own gas resources - Romania; (ii) one with high imports – Germany and (iii) one with total imports of natural gas – Finland.

The data for these countries and for EU30, in two different years i.e. 1990 and 2030, are shown, for gas and oil, in the following table 4 and the associated figure 14.

Table 4 Gas and Oil vulnerability indexes

import/gross inland consumption	Gas		Oil	
	1990	2030	1990	2030
Romania	0.21	0.59	0.59	0.66
Finland	1.00	1.00	1.05	1.07
Germany	0.76	0.91	0.97	1.01
EU 30	0.39	0.66	0.73	0.90

Figure 14 Vulnerability indexes for Natural Gas.

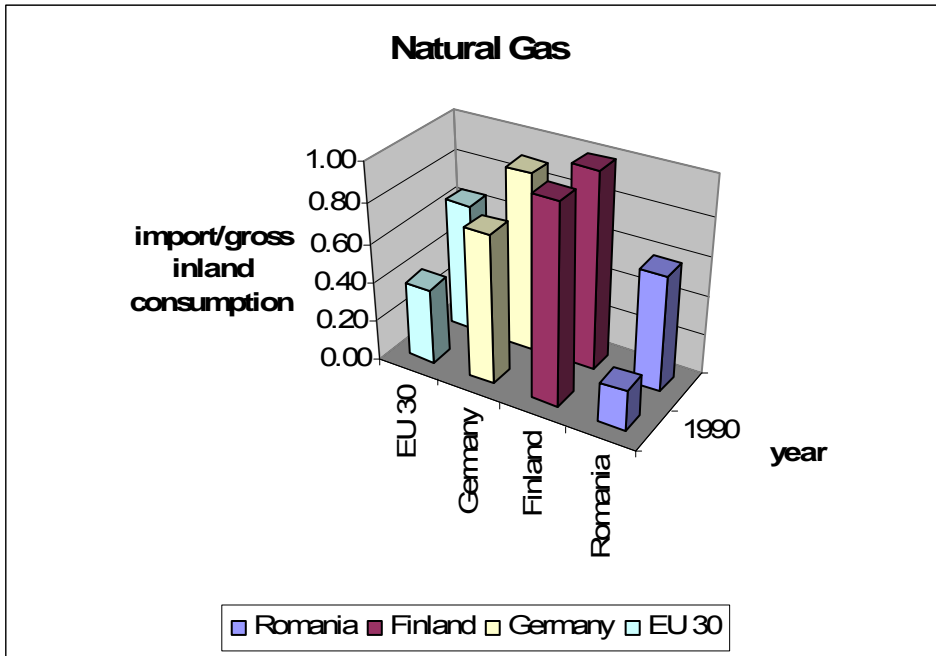

The calculation of the Beta index for behavior is given graphically in the three following figures (figures 15-17).

Figure 15 Beta – behavior coefficient for Romania

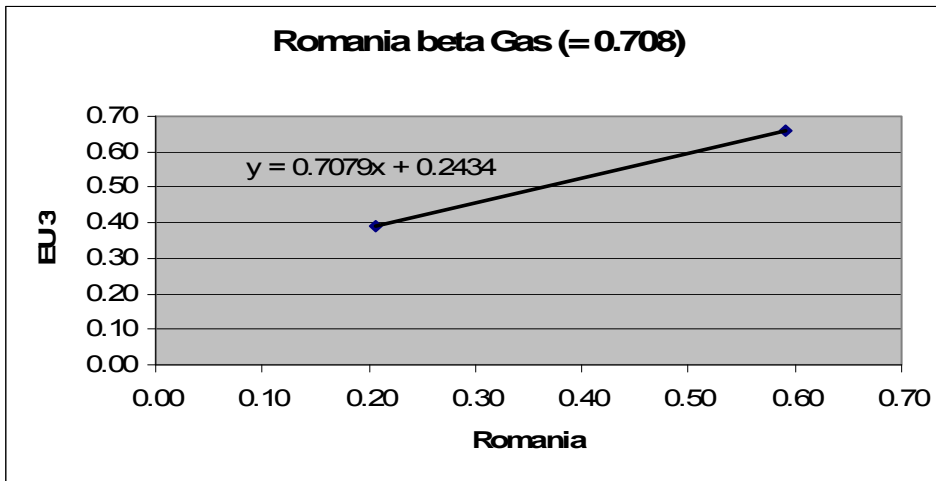

Figure 16 Beta behavior coefficient for Finland

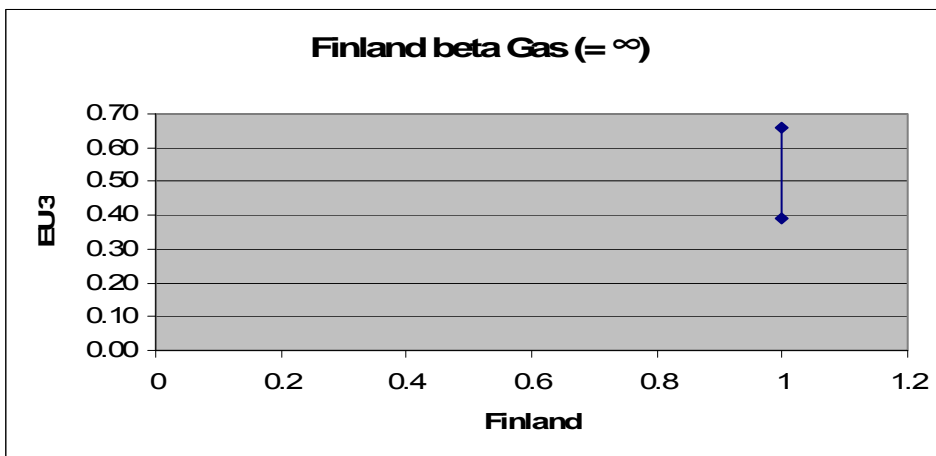
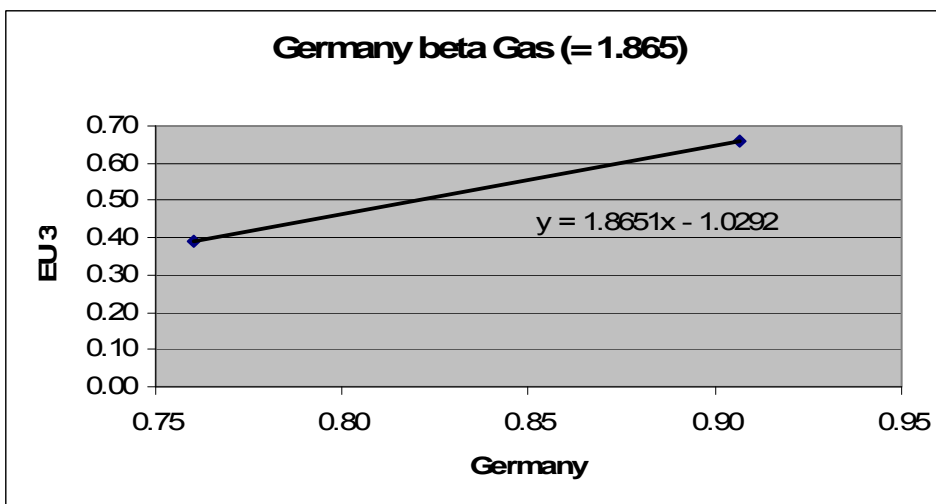

Figure 17 Beta behavior coefficient for Germany



The indexes range from under 1 for Romania to over 1 for Germany and to infinity for Finland. Obviously if a country would have the exact data as EU27 then its index would be 1. The further away the index is from 1, either up or down, the more likely would be the government of that country to deviate from a general EU policy, due to over-perception of either high local vulnerability ($\beta > 1$), or local strength i.e. low local vulnerability ($\beta < 1$).

In order to better view local versus global behavior we have considered the larger view of the three parameters of interest such as GDP (Y), Energy (e) and Emissions (em) that were represented in a contour plot view of the potential function representation. (Purica et.al.2007)

The evolution of the spatial view for the EU is shown in the figure 18 below. A strong dynamic is emerging for the local versus global behavior in the given 'phase space'.

Figure 18 Potential function representation of multi parameter dynamic for EU (source L.L.Albu)

a) **1990**

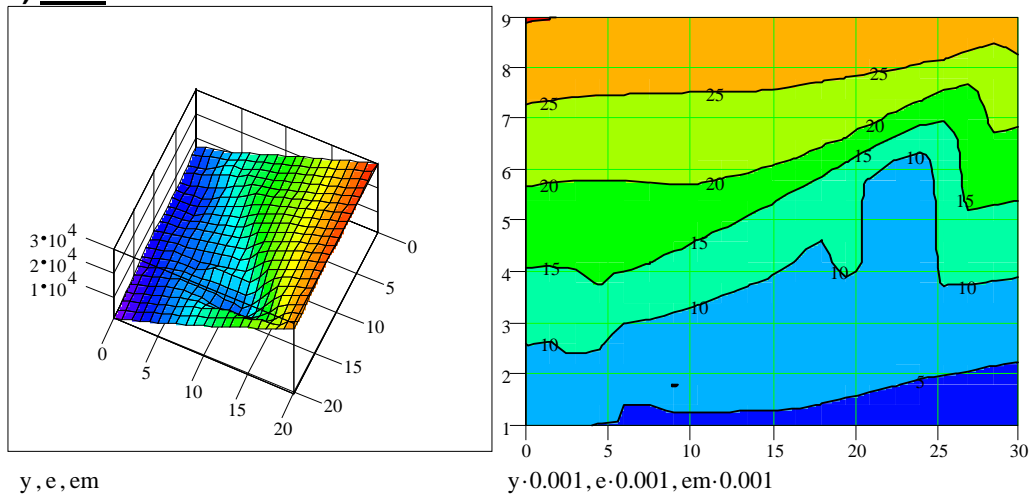

b) 1995

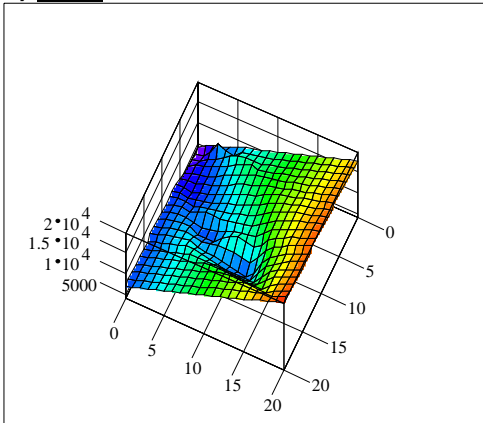

y, e, em

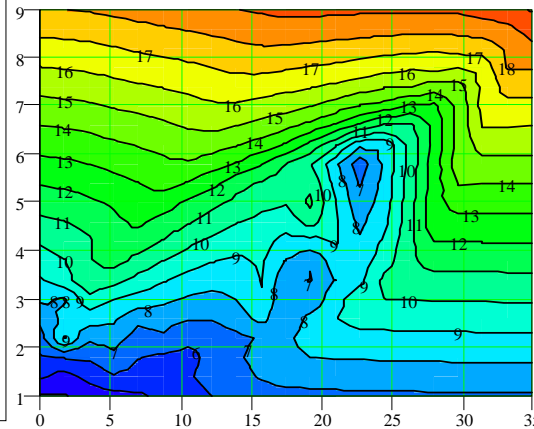

y·0.001, e·0.001, em·0.001

c) 2000

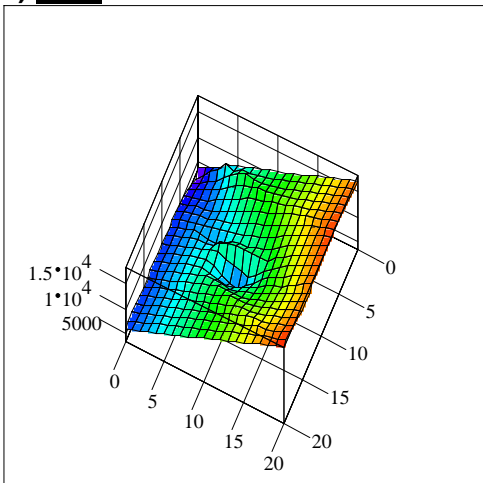

y, e, em

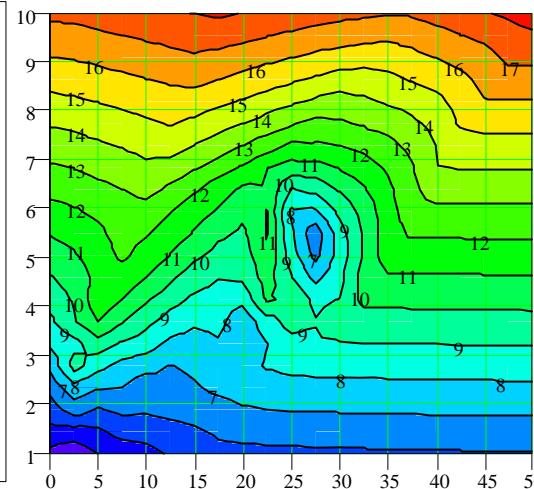

y·0.001, e·0.001, em·0.001

d) 2003

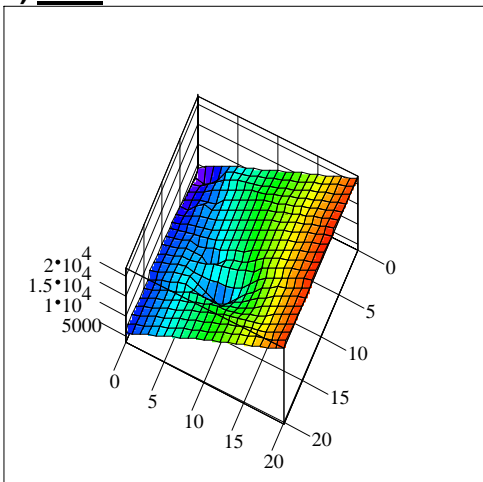

y, e, em

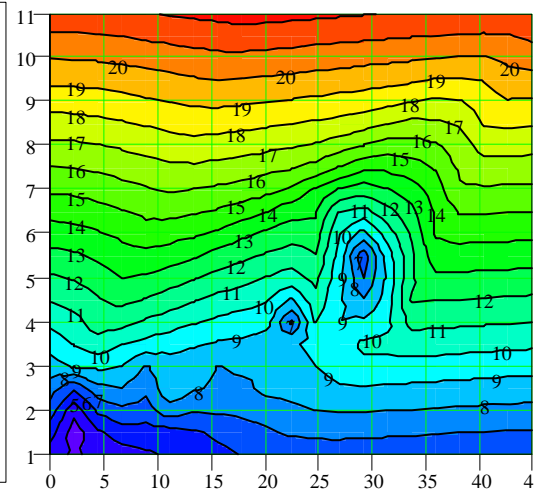

y·0.001, e·0.001, em·0.001

4 Conclusions

The introduction of an index measuring the behavior of member countries that combines local perception of energy vulnerability with the global view of the EU Commission is opening a synthetic way to associate the various energy policy components and possible divergence from a unified EU behavior.

Like in the case of money governed by a single EU Bank, energy imports should probably be governed at the whole level of the EU. The resulting advantages are obvious both in terms of increasing EU cohesion and with regard to the price of gas and oil that would take advantage of the benefits of scale.

Our approach is merely the beginning of a potentially comprehensive program to analyze global versus local energy behavior in the EU. Based on this approach we suggest a wider effort be made to introduce a coherent measurement of energy policy behavior in the EU.

References

EU Commission (2007), EUROPEAN ENERGY AND TRANSPORT Trends to 2030 – update 2005, EU Commission Report.

I.Purica, (2002), Nonlinear Behavior and Crisis Prevention – Center for Conflict Research, Black Sea University Foundation report series, 2002

I.Purica, L.L.Albu, M.Iordan, N.Chilian, (2007) Advanced Models to forecast emissions technical and economic impacts, IPE Research Report, Bucharest, 2007.

WEC, (2007), Energy and Climate Change Report, World Energy Council Report.

Electronic publications of the Pan-European Institute

ISSN 1795-5076

Freely available at <http://www.tse.fi/pei>

2008

14/2008

Vahtra, Peeter — Ehrstedt, Stefan

Russian energy supplies and the Baltic Sea region

13/2008

Baltic Rim Economies Expert Articles 2004-2008

12/2008

Kaartemo, Valteri

Döner Ekonomi – Analysis of Turkish Economy

11/2008

Peltola, Kaisa-Kerttu

Russian innovation system in international comparison - Opportunities and challenges for the future of innovation development in Russia

10/2008

Dezhina, Irina – Peltola, Kaisa-Kerttu

International Learning in Innovation Area: Finnish Experience for Russia

9/2008

Usanov, Artur

Special Economic Zone in Kaliningrad as a Tool of Industrial Development: The Case of the Consumer Electronics Manufacturing

8/2008

Zashev, Peter

Current state and development potential of Russian Special Economic Zones – Case study on the example of Saint Petersburg SEZ

7/2008

Vahtra, Peeter – Zashev, Peter

Russian automotive manufacturing sector – an industry snapshot for foreign component manufacturers

6/2008

Cameron, Fraser – Matta, Aaron

Prospects for EU-Russia relations

5/2008

Krushynska, Tetiana

Ukrainian-Russian economic relations, eurointegration of Ukraine: problems, role, perspectives

4/2008

Ehrstedt, Stefan – Vahtra, Peeter

Russian energy investments in Europe

3/2008

Liuhto, Kari

Genesis of Economic Nationalism in Russia

2/2008

Vahtra, Peeter– Kaartemo, Valteri

Energiaturvallisuus ja ympäristö Euroopan Unionissa - suomalaisyritysten energianäkökulmia

1/2008

Nirkkonen, Tuomas

Chinese Energy Security and the Unipolar World – Integration or confrontation?

2007

19/2007

Nojonen, Matti

The Dragon and the Bear 'facing a storm in common boat' – an overview of Sino-Russian relationship

18/2007

Kaartemo, Valteri (ed.)

New role of Russian enterprises in international business

17/2007

Vahtra, Peeter

Suurimmat venäläisyrietykset Suomessa

16/2007

Jaakkola, Jenni

Income convergence in the enlarged European Union

15/2007

Brunat, Eric

Issues of professional development of labour resources in the Kaliningrad region

14/2007

Dezhina, Irina – Zashev. Peeter

Linkages in innovation system in Russia – Current status and opportunities for Russian-Finnish collaboration

13/2007

Vahtra, Peeter

Expansion or Exodus? The new leaders among the Russian TNCs

12/2007

Kärnä, Veikko

The Russian mining industry in transition

11/2007

Männistö, Marika

Venäjän uudet erityistalousalueet – Odotukset ja mahdollisuudet

10/2007

Kuznetsov, Alexei V.

Prospects of various types of Russian transnational corporations (TNCs)

9/2007

Uiboupin, Janek

Cross-border cooperation and economic development in border regions of Western Ukraine

8/2007

Liuhto, Kari (ed.)

External economic relations of Belarus

7/2007

Kaartemo, Valtteri

The motives of Chinese foreign investments in the Baltic sea region

6/2007

Vahtra, Peeter - Pelto, Elina (eds)

The Future Competitiveness of the EU and Its Eastern Neighbours

5/2007

Lorentz, Harri

Finnish industrial companies' supply network cooperation and performance in Russia

4/2007

Liuhto, Kari

A future role of foreign firms in Russia's strategic industries

3/2007

Lisitsyn, Nikita

Technological cooperation between Finland and Russia: Example of technology parks in St. Petersburg

2/2007

Avdasheva, Svetlana

Is optimal industrial policy possible for Russia? Implications from value chain concept

1/2007

Liuhto, Kari

Kaliningrad, an attractive location for EU Investors

2006

11/2006

Lorentz, Harri

Food supply chains in Ukraine and Kazakhstan

10/2006

Hannula, Kaisa-Kerttu

Doing business in Ukraine - Experiences of two Finnish companies

9/2006

Uiboupin, Janek

Industrial clusters and regional development in Ukraine: the implications of foreign direct investments and trade

8/2006

Avdasheva, Svetlana

Russian furniture industry: Enterprises' upgrading from the value-chain Theory perspectives

7/2006

Food industry value chains in Leningrad oblast and Krasnodar krai
(Finngrain – Vilja-alan yhteistyöryhmä)

6/2006

Zashev, Peter – Vahtra, Peeter

Kazakhstan as a Business Opportunity – Industrial Clusters and Regional Development

5/2006

Keskitalo, Päivi

Internationalisation of Finnish Environmental Technology to Poland

4/2006

Heiskanen, Katja

Internationalisation of Finnish Small and Medium-sized Companies towards the New EU Member States in the Baltic Sea Region

3/2006

Zashev, Peter

Belarus as a Business Opportunity?

2/2006

Johansson, Linda

International Business Operations of Companies with Russian Involvement in Southwestern Finland

1/2006

Vahtra, Peeter

Expansion or Exodus? - Trends and Developments in Foreign Investments of Russia's Largest Industrial Enterprises

2005

10/2005

Hannula, Kaisa-Kerttu

Host Country Determinants and Investment Motives of Finnish FDI in the Publishing Sectors of Bulgaria and Romania

9/2005

Vahtra, Peeter

Russian Investments in the CIS - Scope, Motivations and Leverage

8/2005

Liuhto, Kari - Zashev, Peter - Heiskanen, Katja (ed.)

The Approaching EU Accession of Bulgaria and Romania - New Opportunities for EU Enterprises

7/2005

Liuhto, Kari (ed.)

Kaliningrad 2020: Its Future Competitiveness and Role in the Baltic Sea Economic Region

6/2005

Levando, Dmitry

Investigation into the Structure of Reasoning in Economics

5/2005

Vahtra, Peeter - Pirilä, Hannu - Hietanen, Satu

ICT-sektori Baltiassa ja Puolassa

4/2005

Zashev, Peter

Between the Co-competitors: Belarus, Moldova and Ukraine Economic Integration in a Bi-polar Europe

3/2005

Pirilä, Hannu

Baltian ja Puolan taloudet vuonna 2004 - EU-jäsenyyden ja nopean talouskasvun vuosi

2/2005

Liuhto, Kari - Vincze, Zsuzsanna (ed.)

Wider Europe

1/2005

Lisitsyn, Nikita E. - Sutyryn, Sergei F. - Trofimenko, Olga Y. - Vorobieva, Irina V.

Outward Internationalisation of Russian Leading Telecom Companies



www.tse.fi/pei